

Refrigerator Burner—Detailed Parts List

The world's best absorption refrigerators incorporate this Aladdin burner that is renowned for its quality, reliable operation, and fuel economy.

This high quality burner is ideal for kerosene refrigerators with capabilities between 115 – 225 liters (4-8 cubic feet).

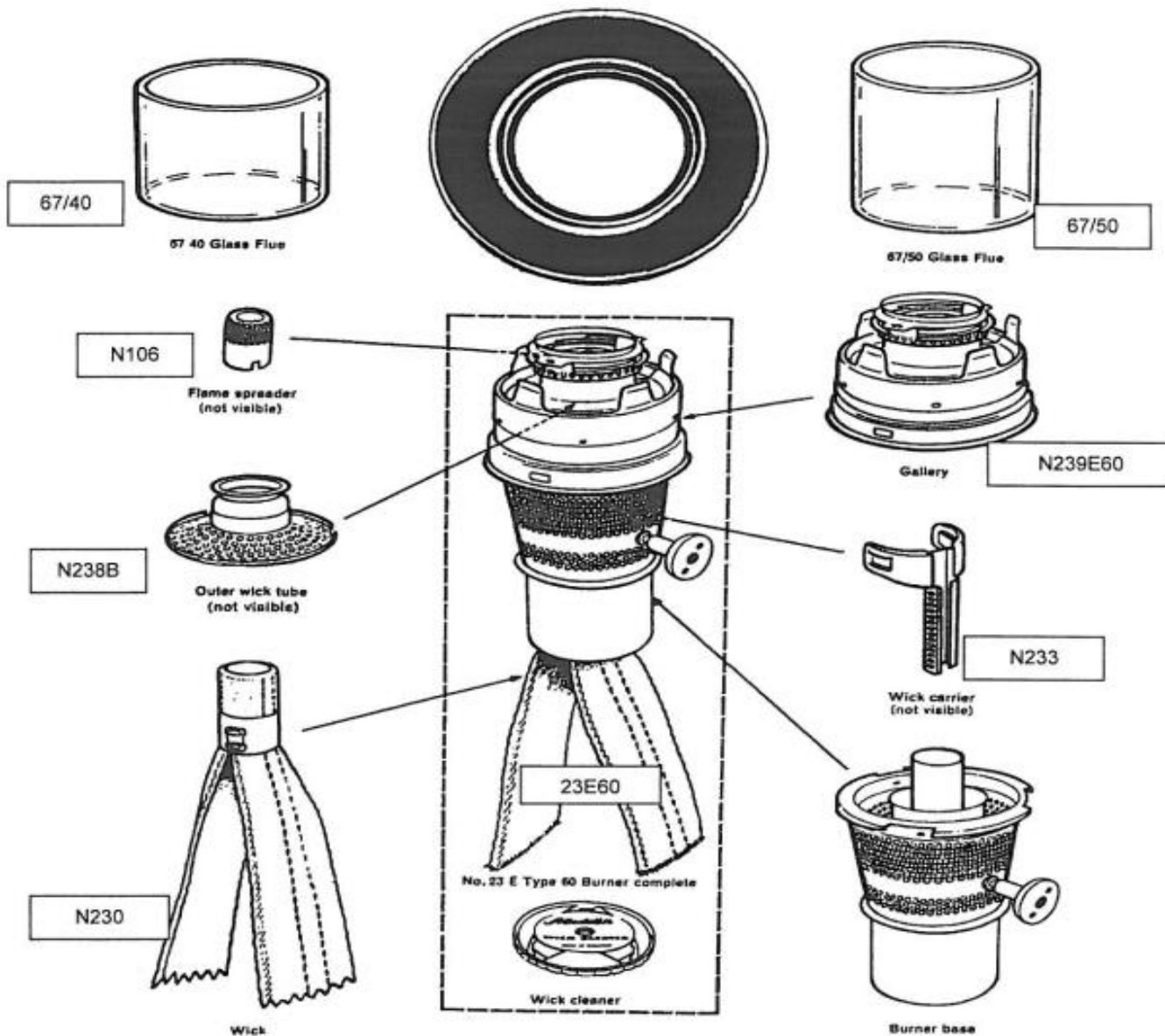

Specifications:

Consumption (kerosene):

45-85 cc/hr, 1.5-2.9 oz/hr

Heat Output: 1,480-2,790 BTU/hr

Crownplace Brands

13110 Emerson Rd

Apple Creek, OH 44606

Phone: (888) 332-5534

Fax: (815) 572-8518

Website: www.aladdinlamps.com

Email: info@crownplacebrands.com



Simply Brilliant™

*"Light where you want it –
When you want it –*

Without the need for electricity."

That's the magic of Aladdin!